

SPECIFICATIONS / 800ENC

Overall Dimensions		Drifter		Boom	
Gross Weight	12,000 kg / 26,455 lbs	Weight	210 kg / 463 lbs	Overall Length	1,500 mm / 4.92 ft
Overall Length	10,516 mm / 34.5 ft	Impact Frequency	40-45 Hz	Lift Angle	45° / 15°
Overall Width	2,490 mm / 8.17 ft	Rotational Torque	Max. 59 kgfm / 427 flbs	Swing Angle	40° / 40°
Overall Height	2,921 mm / 9.58 ft	Rotational Frequency	Max. 150 RPM	Auto Rod Changer	Carousel Type
Crawler		Impact Pressure	Max. 140 bar / 2,031 psi	# of Rod Installed	4+1 EA
Ground Clearance	540 mm / 1.77 ft	Rotation Pressure	Max. 140 bar / 2,031 psi	Air End	
Oscillating Angle	10°	Flushing Pressure	Max 10.5 bar / 150 psi	Working Pressure	10.5 kg-cm ² / 149.3 psi
Gradeability	30°	Bit & Rod		Free Air Delivery	6.6 m ³ / 233 cfm
Traveling Speed	3.8 kmh / 2.36 mph	Bit Diameter	2.5-4.5"	Guide	
Engine Cummins B6.7		Rod Length	3,660 mm / 12 ft	Overall Length	8,103 mm / 26.58 ft
Rated Output	173 bhp / 2,200 rpm	Rod Section	T38/T45/T51	Slide Length	1,500 mm / 4.92 ft
Dust Collector		Hydraulic System		Feed Length	5,800 mm / 19.03 ft
# of Filters	4	Hydraulic Pump	2 Variable Piston Pump + 1 Gear Pump 1 Gear Pump (Cooler)	Swing Angle	40° / 40°
				Tilt Angle	180°

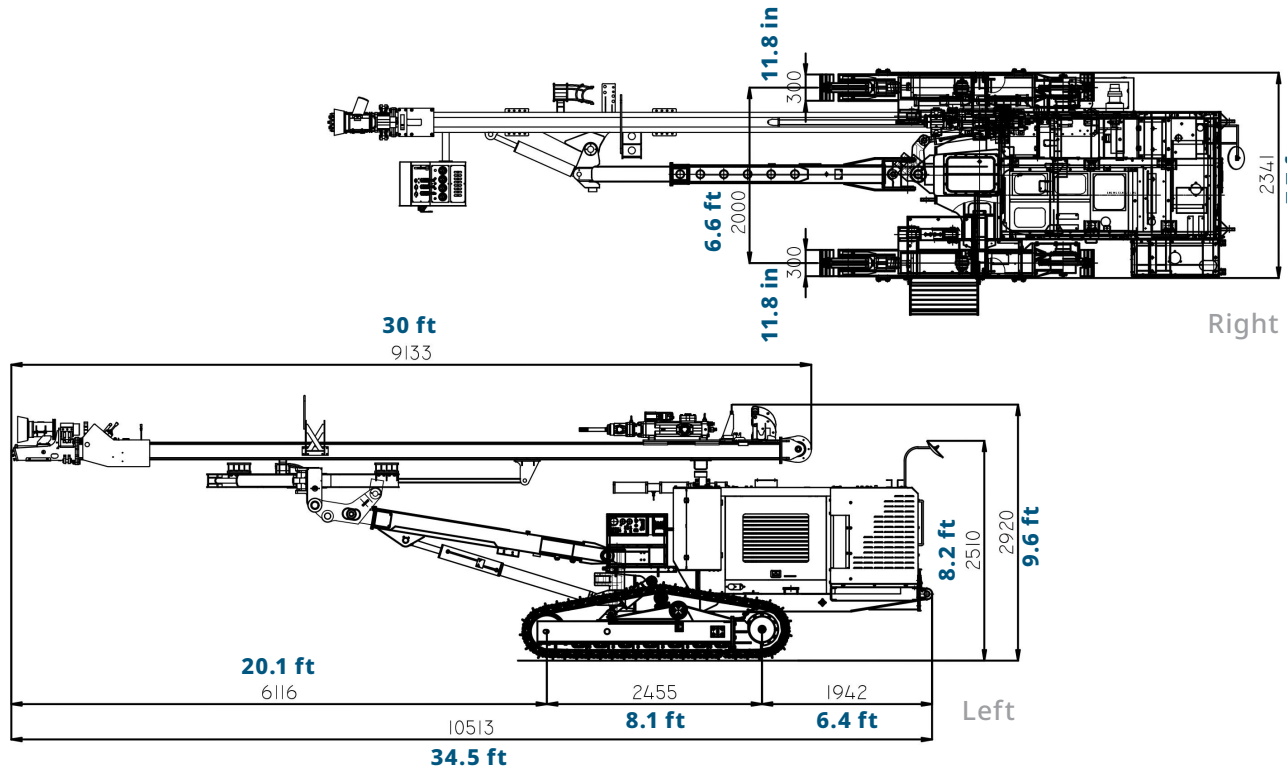

800ENC ROCK COMMANDER

Putting Simplicity
To Work For You!



(502) 244-0004
john@rockdrills.net



SoosanAmerica.com
RockDrills.net

SOOSAN AMERICA LLC. 732 North English Station, Louisville, KY 40223



(502) 244-0004 |
SoosanAmerica.com
RockDrills.net



JD800ENC

ROCK COMMANDER



INDUSTRY PROVEN COMPONENTS

1 →

PROVEN AND RELIABLE YH-80A DRIFTER

This Drifter provides unmatched parts availability and a simple to maintain design. Hole sizes range from 2.75" To 4". Optional T51 drill steel set up available. These units are easy to service and extremely dependable.

YH80A: Impact Power 22hp (16.5kw), Torque 427 ft/lbs. Rotation 150 rpm max.

2 →

SPECIFICALLY PAIRED AIR-END

The Air-End delivers 233 CFM of air at 150 PSI to clear cuttings and power through over-burden. This proven design is in use in hundreds of drilling rigs world-wide. The simple and efficient air system is easy to maintain and troubleshoot if any issue arises.

3 →

KAWASAKI VARIABLE PISTON PUMP

This system delivers the flow to power the main systems of the drill. Kawasaki is an international leader in hydraulic pump technology, powering many different types of equipment around the world. The Kawasaki pumps are quiet and reliable under the harshest of conditions.

4 →

SIMPLE DESIGN SYSTEMS

These systems allow for easy adjustments and maintenance that anyone can understand. The enclosure is designed with room to work. Each of the Rock Commanders systems can be easily accessed and adjusted in the well thought-out design. Simple systems equal maintenance anyone can perform. No technician with a lap-top required.

CUMMINS B6.7 ENGINE

YAMAMOTO YH-80A DRIFTER

DRY DUST COLLECTOR

EXTENDABLE BOOM

KAWASAKI HYDRAULIC PUMPS

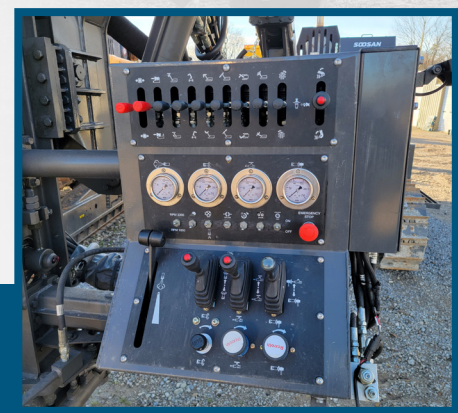

Easy To Use Controls

Adjustments are easily within the operators reach. Easy to read gauges to help you monitor the drilling process.

No On-board Computer

Limit down-time and electronic failure. No waiting on electronic parts and service technicians.



Round Carousel

Rod changer with 4 + 1 capacity that is simple with minimal moving parts. Starts 16ft rod and changes 12ft sections.

Dry Dust Collector

Four easy to replace and inexpensive filter elements. Optional water injection system available with American made ASME pressure vessel.



Digital Angle Indicator

This system keeps you straight even in the toughest drilling conditions.

Cummins B6.7 Engine

Provided with a two year manufacturer's warranty. Dependable and easily serviceable power pack with the support of your local Cummins dealer.